

# IEEE 1394-Based Digital Camera ORCA-285



The ORCA-285 is a high resolution digital camera using a progressive scan interline CCD chip with no mechanical shutter. In addition to a high resolution of 1.37 million pixels, a wide dynamic range of 12 bit digital output and high sensitivity offers a wide application range down to low light level imaging. Peltier cooling drastically reduces dark noise and minimizes thermal drift, which makes camera an ideal choice for demanding scientific and industrial application.

A high performance serial bus IEEE 1394 is used as a computer interface. Furthermore, a standard C-mount lens coupling makes it easy to connect to optics such as optical microscopes.

## APPLICATIONS

- Routine Fluorescence Microscopy
- Green Fluorescent Protein applications
- DNA and Ploidy analysis
- Red and Near infrared fluorescent applications
- Fluorescence In Situ Hybridization studies
- Motility and Motion analysis
- Combined DIC/Phase and Fluorescence
- Histology, Pathology and Cytology
- Metallurgical microscopy
- Failure analysis
- Semiconductor inspection
- X-ray scintillator readout

## SPECTRAL RESPONSE CHARACTERISTIC

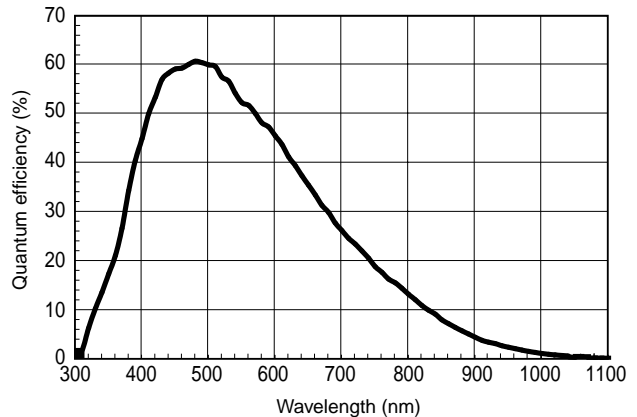

★ This is typical, not guaranteed

## FEATURES

- High resolution of 1.37 million pixels
- Progressive scan interline CCD chip with no mechanical shutter
- Approx. 10  $\mu$ s electronic shutter to capture fast events
- Binning ( $2 \times 2$ ,  $4 \times 4$ ,  $8 \times 8$ ) function to improve sensitivity and achieve a frame rate up to 41 Hz
- Low dark noise with peltier cooling for a dynamic range of more than 60dB
- Compatible with IIDC 1394-based digital camera specification
- Full remote control from PC via IEEE 1394 bus

## SYSTEM CONFIGURATION

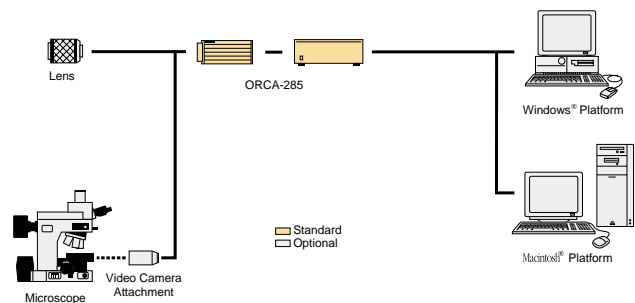

## SPECIFICATIONS

Type number	C4742-95-12G04		
Camera head type	Passive air-cooled head		
Imaging device	ICX-285 progressive scan interline CCD		
Effective number of pixels	1344 (H) X 1024 (V)		
Cell size	6.45 μm (H) X 6.45 μm (V)		
Effective area	8.67 mm (H) X 6.60 mm (V)		
Pixel clock rate	14.75 MHz/pixel		
Frame rate	binning	1 X 1	8.8 frame/s
		2 X 2	16 frame/s
		4 X 4	27 frame/s
		8 X 8	41 frame/s
Readout noise (r.m.s.) typ.	8 electrons		
Full well capacity typ.	18000 electrons		
Dynamic range* typ.	2250 : 1		
Cooling method	Peltier cooling, air radiation system		
Cooling temperature	+ 5 °C		
Dark current	0.8 electrons/pixel/s		
A/D converter	12 bit		
Exposure time	10 μs to 10 s		
Sub-array	yes		
Contrast enhancement	Analog gain (10times max.) and offset function		
External trigger	yes		
Lens mount	C-mount		
Interface / Output signal (digital output)	IEEE1394-1995 / Non-compressed data (Mono 16)		
External control	IIDC 1394-Based Digital Camera Specification Ver.1.30		
Line voltage	AC 100 V / AC 117 V / AC 220 V / AC 240 V, 50/60 Hz		
Power consumption	approx. 70VA		
Ambient storage temperature	- 10 °C to + 50 °C		
Ambient operating temperature	0 °C to + 40 °C		
Ambient storage/operating humidity	70 % max. ( no condensation)		

\*Calculated from the ratio of the full well capacity and the readout noise

## DIMENSIONAL OUTLINES (Unit: mm)

### • Camera head (approx. 1.3 kg)

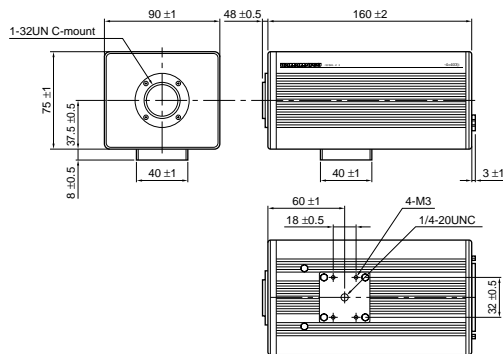

### • Camera controller (approx. 6.3 kg)

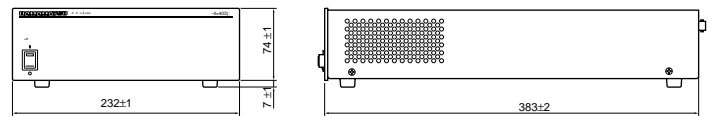

- ★ Macintosh is registered trademark of Apple Computer, Inc.
  - ★ Windows is registered trademark of Microsoft Corporation in the U.S.A.
  - ★ Product and software package names noted in this documentation are trademarks or registered trademarks of their respective manufacturers.
  - Subject to local technical requirements and regulations, availability of products included in this promotional material may vary. Please consult with our sales office.
  - Information furnished by HAMAMATSU is believed to be reliable. However, no responsibility is assumed for possible inaccuracies or omissions.
- Specifications and external appearance are subject to change without notice.

© 2003 Hamamatsu Photonics K.K.



# HAMAMATSU

Homepage Address <http://www.hamamatsu.com>

HAMAMATSU PHOTONICS K.K., Systems Division

812 Joko-cho, Hamamatsu City, 431-3196, Japan, Telephone: (81)53-431-0124, Fax: (81)53-435-1574, E-mail: [export@sys.hpk.co.jp](mailto:export@sys.hpk.co.jp)

U.S.A. and Canada: Hamamatsu Photonic Systems: 360 Foothill Road, Bridgewater, N.J. 08807-0910, U.S.A., Telephone: (1)908-231-1116, Fax: (1)908-231-0852, E-mail: [usa@hamamatsu.com](mailto:usa@hamamatsu.com)

Germany: Hamamatsu Photonics Deutschland GmbH: Arzbergerstr. 10, D-82211 Herrsching am Ammersee, Germany, Telephone: (49)8152-375-0, Fax: (49)8152-2658, E-mail: [info@hamamatsu.de](mailto:info@hamamatsu.de)

France: Hamamatsu Photonics France S.A.R.L.: 8, Rue du Saule Trapu, Parc du Moulin de Massy, 91882 Massy Cedex, France, Telephone: (33)1 69 53 71 00, Fax: (33)1 69 53 71 10, E-mail: [infos@hamamatsu.fr](mailto:infos@hamamatsu.fr)

United Kingdom: Hamamatsu Photonics UK Limited: 2 Howard Court, 10 Tewin Road, Welwyn Garden City, Hertfordshire, AL7 1BW, U.K., Telephone: (44)1707-294888, Fax: (44)1707-325777, E-mail: [info@hamamatsu.co.uk](mailto:info@hamamatsu.co.uk)

North Europe: Hamamatsu Photonics Norden AB: Smidesvägen 12, SE-171-41 Solna, Sweden, Telephone: (46)8-509-031-00, Fax: (46)8-509-031-01, E-mail: [info@hamamatsu.se](mailto:info@hamamatsu.se)

Italy: Hamamatsu Photonics Italia S.R.L.: Strada della Mois, 1/E 20020 Arese (Milano), Italy, Telephone: (39)02-935 81 733, Fax: (39)02-935 81 741, E-mail: [info@hamamatsu.it](mailto:info@hamamatsu.it)

Cat. No. SICS1113E02

MAY/2003 HPK

Created in Japan (PDF)