

Getting Started with the NI PCIe-1429 and NI PCIe-1430

The NI PCIe-1429 and NI PCIe-1430 are highly flexible PCI Express (PCIe) image acquisition devices. The NI 1429 supports Base, Medium, and Full configuration Camera Link-compatible cameras. The NI 1430 supports up to two Base configuration Camera Link-compatible cameras. The following sections describe how to get started using the NI 1429 and NI 1430.

Conventions

The following conventions are used in this manual:



The ♦ symbol indicates that the following text applies only to a specific product.



This icon denotes a note, which alerts you to important information.



This icon denotes a caution, which advises you of precautions to take to avoid injury, data loss, or a system crash. When this symbol is marked on a product, refer to the [Safety Information](#) section for information about precautions to take.

bold

Bold text denotes items that you must select or click in the software, such as menu items and dialog box options. Bold text also denotes parameter names.

italic

Italic text denotes variables, emphasis, a cross reference, or an introduction to a key concept. Italic text also denotes text that is a placeholder for a word or value that you must supply.

monospace

Text in this font denotes text or characters that you should enter from the keyboard, sections of code, programming examples, and syntax examples. This font is also used for the proper names of disk drives, paths, directories, programs, subprograms, subroutines, device names, functions, operations, variables, filenames, and extensions.

Installing the NI 1429 and NI 1430

The following sections contain lists of necessary and optional items for acquiring images with the NI 1429 and NI 1430. These sections also contain important safety information and instructions for unpacking, installing, and configuring the NI 1429 and NI 1430.

What You Need to Get Started

You need the following items to set up and use the NI 1429 and the NI 1430:

- Getting Started with NI-IMAQ* CD Insert
- NI-IMAQ for Windows 2000/XP and documentation



Note PDFs of the NI-IMAQ for Windows 2000/XP documentation are installed on your computer at <NI-IMAQ>\Docs, where <NI-IMAQ> is the location to which you installed NI-IMAQ.

- Computer running Windows 2000/XP with at least one x4 PCIe slot



Note For some computers, a PCIe slot larger than x4 may be used. Refer to the [Installation](#) section for more information.

- Cameras and cables
 - ◆ NI 1429
 - Camera Link-compatible camera
 - One MDR 26-pin Camera Link cable for Base configuration cameras
 - Two MDR 26-pin Camera Link cables of the same length for Medium or Full configuration cameras
 - ◆ NI 1430
 - Up to two Base configuration Camera Link-compatible cameras
 - One MDR 26-pin Camera Link cable per Base configuration camera
- Optional software packages and documentation:
 - NI Vision for LabVIEW, LabWindows™/CVI™, or Visual Basic
 - Vision Builder for Automated Inspection
 - LabVIEW

- LabWindows/CVI
- Visual Basic

Optional Equipment

National Instruments offers a variety of products for use with the NI 1429 and the NI 1430, including the following:

- NI Camera Link I/O Extension Board for enhanced I/O capabilities
- SMB to BNC cable, used for front panel trigger I/O
- RTSI bus cable, used to connect the NI 1429 and NI 1430 to other National Instruments Vision, Motion Control, or Data Acquisition (DAQ) devices
- Other NI Vision, Motion Control, or DAQ devices for enhanced triggering, timing, or I/O

For more information about these products, refer to the National Instruments catalog, visit ni.com, or call the National Instruments office nearest you.

Safety Information



Caution The following paragraphs contain important safety information you *must* follow when installing and operating the device.

Do *not* operate the device in a manner not specified in the documentation. Misuse of the device may result in a hazard and may compromise the safety protection built into the device. If the device is damaged, turn it off and do *not* use it until service-trained personnel can check its safety. If necessary, return the device to National Instruments for repair.

Keep away from live circuits. Do *not* remove equipment covers or shields unless you are trained to do so. If signal wires are connected to the device, hazardous voltages can exist even when the equipment is turned off. To avoid a shock hazard, do *not* perform procedures involving cover or shield removal unless you are qualified to do so. Disconnect all field power prior to removing covers or shields.

If the device is rated for use with hazardous voltages ($>30 V_{\text{rms}}$, $42.4 V_{\text{pk}}$, or $60 V_{\text{dc}}$), it may require a safety earth-ground connection wire. Refer to the device specifications for maximum voltage ratings.

Because of the danger of introducing additional hazards, do *not* install unauthorized parts or modify the device. Use the device only with the chassis, modules, accessories, and cables specified in the installation instructions. All covers and filler panels *must* be installed while operating the device.

Do *not* operate the device in an explosive atmosphere or where flammable gases or fumes may be present. Operate the device only at or below the pollution degree stated in the specifications. Pollution consists of any foreign matter—solid, liquid, or gas—that may reduce dielectric strength or surface resistivity. The following is a description of pollution degrees.

- Pollution Degree 1—No pollution or only dry, nonconductive pollution occurs. The pollution has no effect.
- Pollution Degree 2—Normally only nonconductive pollution occurs. Occasionally, nonconductive pollution becomes conductive because of condensation.
- Pollution Degree 3—Conductive pollution or dry, nonconductive pollution occurs. Nonconductive pollution becomes conductive because of condensation.

Clean the device and accessories by brushing off light dust with a soft, nonmetallic brush. Remove other contaminants with a stiff, nonmetallic brush. The unit *must* be completely dry and free from contaminants before returning it to service.

You *must* insulate signal connections for the maximum voltage for which the device is rated. Do *not* exceed the maximum ratings for the device. Remove power from signal lines before connection to or disconnection from the device.



Caution National Instruments measurement products may be classified as either Measurement Category I or II. Operate products at or below the Measurement Category level specified in the hardware specifications.

Measurement Category¹: Measurement circuits are subjected to working voltages² and transient stresses (overvoltage) from the circuit to which they are connected during measurement or test. Measurement Category establishes standardized impulse withstand voltage levels that commonly occur in electrical distribution systems. The following is a description of Measurement (Installation³) Categories:

¹ Measurement Categories as defined in electrical safety standard IEC 61010-1.

² Working voltage is the highest rms value of an AC or DC voltage that can occur across any particular insulation.

³ Measurement Category is also referred to as Installation Category.

- Measurement Category I is for measurements performed on circuits *not* directly connected to the electrical distribution system referred to as MAINS¹ voltage. This category is for measurements of voltages from specially protected secondary circuits. Such voltage measurements include signal levels, special equipment, limited-energy parts of equipment, circuits powered by regulated low-voltage sources, and electronics.
- Measurement Category II is for measurements performed on circuits directly connected to the electrical distribution system. This category refers to local-level electrical distribution, such as that provided by a standard wall outlet (e.g., 115 V for U.S. or 230 V for Europe). Examples of Measurement Category II are measurements performed on household appliances, portable tools, and similar products.
- Measurement Category III is for measurements performed in the building installation at the distribution level. This category refers to measurements on hard-wired equipment such as equipment in fixed installations, distribution boards, and circuit breakers. Other examples are wiring, including cables, bus-bars, junction boxes, switches, socket-outlets in the fixed installation, and stationary motors with permanent connections to fixed installations.

Unpacking

The NI 1429 and NI 1430 ship in antistatic packages to prevent electrostatic discharge from damaging device components. To avoid such damage in handling your device, take the following precautions:

- Ground yourself via a grounding strap or by holding a grounded object, such as the computer chassis.
- Touch the antistatic package to a metal part of the computer chassis before removing the device from the package.



Caution *Never* touch the exposed pins of connectors.

Remove the device from the package and inspect it for loose components or any other signs of damage. Notify National Instruments if the device appears damaged in any way. Do *not* install a damaged device in the computer.

Store the NI 1429 and NI 1430 in the antistatic package when not in use.

¹ MAINS is defined as the (hazardous live) electrical supply system to which equipment is designed to be connected for the purpose of powering the equipment. Suitably rated measuring circuits may be connected to the MAINS for measuring purposes.

Installation

The following instructions are for general installation. Refer to the documentation provided by your computer manufacturer for specific instructions and warnings. Refer to the *Specifications* section for a list of the typical power requirements for the NI 1429 and NI 1430.

1. Install the NI-IMAQ driver software before installing the NI 1429 or NI 1430.
 - ◆ NI 1429—Install NI-IMAQ version 3.1 or later.
 - ◆ NI 1430—Install NI-IMAQ version 3.5 or later.



Note For information about how to install NI-IMAQ, refer to the *Getting Started with NI-IMAQ CD Insert*.

2. Power off and unplug the computer.



Caution To protect yourself and the computer from electrical hazards, the computer *must* remain unplugged until the installation is complete.

3. Remove the computer cover to expose the expansion slots.



Caution Installing a PCIe device into a PCI, PCI-X, AGP, or any non-PCIe slot can damage both the computer motherboard and the device. If you are unsure of the difference between connector types, do not install the device. Refer to the documentation provided by your computer manufacturer to determine the correct slot in which to install the NI 1429 and NI 1430.

4. Choose an unused x4 or larger PCIe slot, and remove the corresponding expansion slot cover on the back panel of the computer.



Note The NI 1429 and NI 1430 are intended for a x4 PCIe slot. They will not fit properly into a x1 PCIe slot. The NI 1429 and NI 1430 will fit into, and can be used in, a x8 or x16 PCIe slot. Using a smaller width device in a larger width slot is called up-plugging. When up-plugging, some motherboards only support plug-in devices at the x1 data rate. If you plan to use the NI 1429 or NI 1430 in an up-plugging configuration, with a camera that produces data faster than 200 MB/s, verify with your computer manufacturer that your motherboard will support a x4 plug-in device at a x4 data rate in the PC expansion slot you plan to use.

Refer to Figure 1 for a diagram that can help you identify different types of expansion slots in your computer.

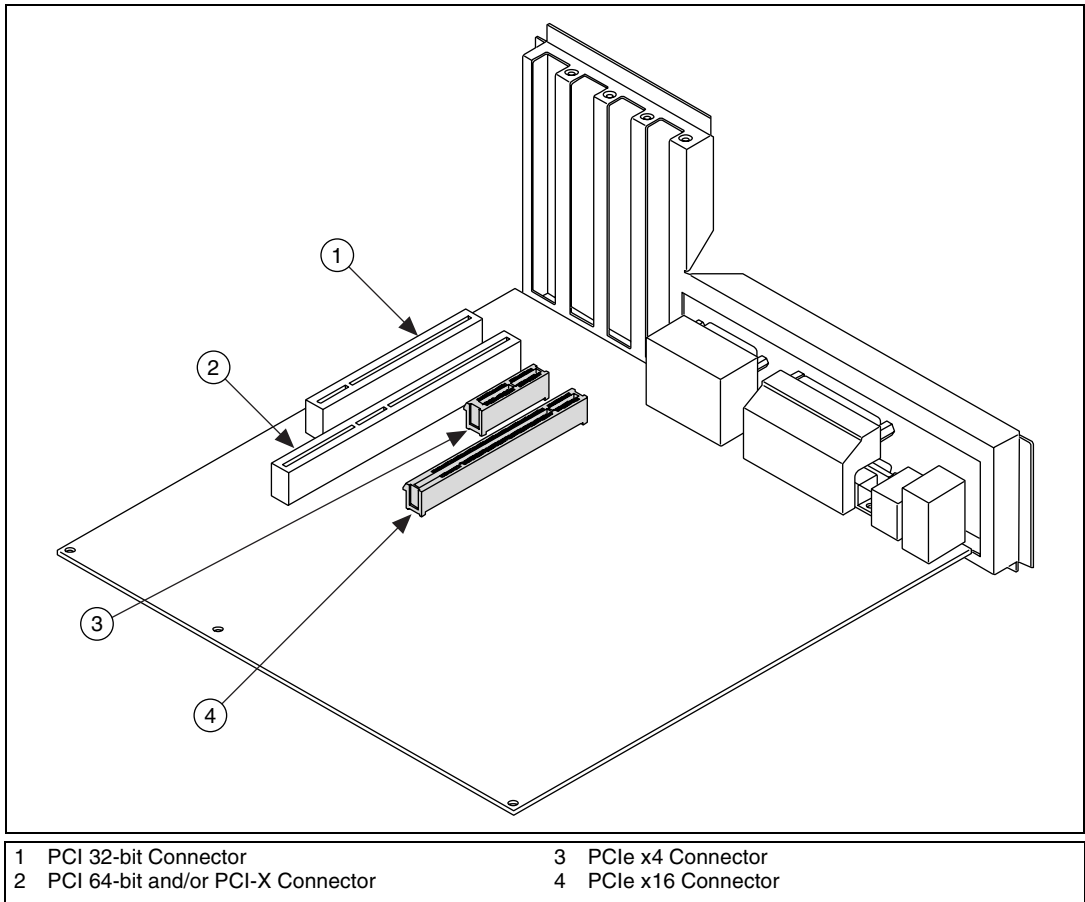

Figure 1. PC Expansion Slots

5. Touch a metal part on the computer case to discharge any static electricity that might be on your clothes or body before handling the NI 1429 or NI 1430. Static electricity can damage the device.
6. Remove your device from the antistatic package and gently rock the device into the slot. The connection may be tight, but do *not* force the device into place.



Note Check that the bracket of your device aligns up with the hole in the back panel rail of the computer chassis.

7. Unless your computer secures expansion devices in a different manner, screw the mounting bracket of the device to the back panel rail of the computer.



Note If you will be using the NI Camera Link I/O Extension Board, refer to the *NI Camera Link I/O Extension Board User Guide* for installation instructions.

8. Replace the computer cover.
9. Plug in and power on the computer.

Your device is now installed.

Configuring the NI 1429 and NI 1430

After you have installed the NI 1429 or NI 1430 and powered on your computer, Windows will recognize the device and assign resources to it. Use Measurement & Automation Explorer (MAX), the National Instruments configuration utility, to configure the NI 1429 and NI 1430 for acquisition.



Note Before configuring the device in MAX, ensure that you installed NI-IMAQ 3.1 or later for the NI 1429 or NI-IMAQ 3.5 or later for the NI 1430.

Interfacing with the NI 1429 and NI 1430

The Camera Link standard defines physical connections between image acquisition devices and Camera Link cameras, and it allows for flexibility of image format and data transfer protocols. The camera manufacturer defines image parameters, such as image resolution and the number of bits per pixel, and camera control parameters, such as frame-on-demand and exposure control signals.

These variable parameters are defined on a per-camera basis in a camera file (`<camera_model>.icd`) supplied by National Instruments. NI-IMAQ uses the information in this camera file to program the NI 1429 and NI 1430 to acquire images from a specific camera. Without this camera file, the driver does not have the information necessary to configure the NI 1429 and NI 1430 to recognize the image format of the particular camera you are using. Refer to MAX for information about valid camera attributes for your camera and image acquisition device.

Many camera files are installed when you install NI-IMAQ, and many more are available for download from the National Instruments Camera Advisor at ni.com/camera. You can also create your own camera files using the NI Camera File Generator. This utility can be downloaded from ni.com/vision. When installing new camera files, save them to the `<NI-IMAQ>\Data` directory.

Contact National Instruments technical support to request camera files not available in the Camera Advisor.

MAX provides a simple interface for associating a camera file with the NI 1429 and NI 1430. Use the following guidelines to access the camera file in MAX:

- ◆ NI 1429
 1. Launch MAX.
 2. Expand the **Devices and Interfaces** branch of the configuration tree.
 3. Expand the **NI-IMAQ Devices** branch.
 4. Expand the **NI PCIe-1429** branch.
 5. Right-click **Channel 0** and select **Camera**.
 6. Select your camera from the menu. If your camera is not in the menu, verify that the appropriate camera file is installed in the <NI-IMAQ>\Data directory.

- ◆ NI 1430
 1. Launch MAX.
 2. Expand the **Devices and Interfaces** branch of the configuration tree.
 3. Expand the **NI-IMAQ Devices** branch.
 4. Expand the **NI PCIe-1430** branch.
 5. Right-click **Port 0** or **Port 1** and select **Camera**.
 6. Select your camera from the menu. If your camera is not in the menu, verify that the appropriate camera file is installed in the <NI-IMAQ>\Data directory.



Note If you lose communication with the camera during an acquisition for any reason, such as unplugging a cable or powering off your camera, you must restart the acquisition to allow the device to relock the incoming timing signals.



Note The NI 1429 and NI 1430 are each equipped with a temperature monitor. The device will stop acquiring images if it reaches its maximum allowable temperature. An error will occur, reporting that the maximum temperature has been reached.

Specifications

These specifications apply to the NI PCIe-1429 and the NI PCIe-1430. These specifications are typical at 25 °C, unless otherwise stated.

External Connections

Number of external trigger I/O lines	1
External trigger lines	
Voltage range.....	0 to 5 V (TTL)
V _{IH} min.....	2.0 V
V _{IL} max	0.8 V
V _{OH} min.....	2.4 V at 8 mA source
V _{OL} max	0.55 V at 8 mA sink
Polarity	Programmable, active-high or active-low
Power-on state	Input (high-impedance) 22.1 kΩ pull-down to ground
Camera interface.....	Camera Link 1.1

Clocks

Pixel clock frequency range.....	20 MHz to 85 MHz ¹
----------------------------------	-------------------------------



Note The Camera Link specification requires cameras to transmit at a minimum of 20 MHz.

PCI Express Interface

PCI Express compliance	Version 1.0a
Native link width	x4
Up-plugging link width availability	x8, x16



Note Some system devices limit data transfer rates for plug-in devices in an up-plugging configuration. Refer to the documentation provided by your computer manufacturer to determine if your computer will support a x4 plug-in device at a x4 data rate in a larger slot.

¹ This value corresponds to the serialized Camera Link cable transmission rate of 140 to 595 MHz.

Serial Interface

Baud rates supported..... 300, 600, 1200, 1800, 2000, 2400,
3600, 4800, 7200, or 9600 bps;
19.2, 38.4, 56, or 115.2 kbps

Power Requirements

Voltage +12 V (1.25 A)¹

Physical

Dimensions..... 10.7 cm × 17.5 cm
(4.2 in. × 6.9 in.)

Weight..... 205 g (7.23 oz)

Environment

The NI PCIe-1429 and NI PCIe-1430 are intended for indoor use only.

Operating temperature..... 0 °C to 40 °C²

Storage temperature –20 °C to 70 °C

Relative humidity 5% to 90%, noncondensing

Pollution Degree 2

Approved at altitudes up to 2,000 m.

Safety

The NI PCIe-1429 and NI PCIe-1430 are designed to meet the requirements of the following standards of safety for electrical equipment for measurement, control, and laboratory use:

- IEC 61010-1, EN 61010-1
- UL 61010-1
- CAN/CSA-C22.2 No. 61010-1



Note For UL and other safety considerations, refer to the product label, or visit ni.com/certification, search by model number or product line, and click the appropriate link in the Certification column.

¹ If you are using special firmware add-ons, this value is subject to change. Consult your firmware upgrade documentation for specific requirements.

² This temperature value was determined through testing the device in a Dell Precision 470 workstation with two adjacent plug-in devices each dissipating 11.6 W.

Electromagnetic Compatibility

EmissionsEN 55011 Class A at 10 m
FCC Part 15A above 1 GHz

ImmunityEN 61326:1997 + A2:2001,
Table 1

CE, C-Tick, and FCC Part 15 (Class A) Compliant



Note For EMC compliance, operate this device with shielded cabling.

CE Compliance

This product meets the essential requirements of applicable European Directives, as amended for CE marking, as follows:

Low-Voltage Directive (safety)..... 73/23/EEC

Electromagnetic Compatibility
Directive (EMC)89/336/EEC



Note Refer to the Declaration of Conformity (DoC) for this product for any additional regulatory compliance information. To obtain the DoC for this product, visit ni.com/certification, search by model number or product line, and click the appropriate link in the Certification column.



Note The NI 1429 and NI 1430 may experience temporary data interruption if exposed to electrostatic discharge (ESD).

Where to Go for Support

The National Instruments Web site is your complete resource for technical support. At ni.com/support you have access to everything from troubleshooting and application development self-help resources to email and phone assistance from NI Application Engineers.

A Declaration of Conformity (DoC) is our claim of compliance with the Council of the European Communities using the manufacturer's declaration of conformity. This system affords the user protection for electronic compatibility (EMC) and product safety. You can obtain the DoC for your product by visiting ni.com/certification. If your product supports calibration, you can obtain the calibration certificate for your product at ni.com/calibration.

National Instruments corporate headquarters is located at 11500 North Mopac Expressway, Austin, Texas, 78759-3504. National Instruments also has offices located around the world to help address your support needs. For telephone support in the United States, create your service request at ni.com/support and follow the calling instructions or dial 512 795 8248. For telephone support outside the United States, contact your local branch office:

Australia 1800 300 800, Austria 43 0 662 45 79 90 0,
Belgium 32 0 2 757 00 20, Brazil 55 11 3262 3599,
Canada 800 433 3488, China 86 21 6555 7838,
Czech Republic 420 224 235 774, Denmark 45 45 76 26 00,
Finland 385 0 9 725 725 11, France 33 0 1 48 14 24 24,
Germany 49 0 89 741 31 30, India 91 80 51190000,
Israel 972 0 3 6393737, Italy 39 02 413091, Japan 81 3 5472 2970,
Korea 82 02 3451 3400, Lebanon 961 0 1 33 28 28,
Malaysia 1800 887710, Mexico 01 800 010 0793,
Netherlands 31 0 348 433 466, New Zealand 0800 553 322,
Norway 47 0 66 90 76 60, Poland 48 22 3390150,
Portugal 351 210 311 210, Russia 7 095 783 68 51,
Singapore 1800 226 5886, Slovenia 386 3 425 4200,
South Africa 27 0 11 805 8197, Spain 34 91 640 0085,
Sweden 46 0 8 587 895 00, Switzerland 41 56 200 51 51,
Taiwan 886 02 2377 2222, Thailand 662 278 6777,
United Kingdom 44 0 1635 523545

National Instruments, NI, ni.com, and LabVIEW are trademarks of National Instruments Corporation. Refer to the *Terms of Use* section on ni.com/legal for more information about National Instruments trademarks. Other product and company names mentioned herein are trademarks or trade names of their respective companies. For patents covering National Instruments products, refer to the appropriate location: **Help»Patents** in your software, the `patents.txt` file on your CD, or ni.com/patents.