

NERLITE® LT430 BL 200x250 LED Backlight Series

Description: NERLITE LT430 Backlight Series (patent pending) provide sharp contrast to outline a part's shape, find edges and view openings such as drilled holes, allowing for various vision operations. In a low-profile industrial package providing optimal thermal management to the LEDs, models in the 200x250 series are a cost effective choice for applications where illuminated area size and uniformity are of importance. NERLITE LT430 Backlights are available in various wavelengths for strobe or continuous duty-cycles, all using industry standard M12 connectors.

Applications: Back lighting: to outline a parts shape, find edges, or detect openings (e.g. drilled holes).

| Part # | Description |
|--------------------|---------------------------------------|
| 6GF3910-0AG00-3AF0 | NERLITE LT430 BL 200x250, R LED-D, CC |
| 6GF3910-0AG00-3AG0 | NERLITE LT430 BL 200x250, W LED-D, CC |
| 6GF3910-0AG00-3AC0 | NERLITE LT430 BL 200x250, B LED-D, CC |
| 6GF3910-0AG00-3AH0 | NERLITE LT430 BL 200x250, G LED-D, CC |
| 6GF3910-0AG00-3AJ0 | NERLITE LT430 BL 200x250, I LED-D, CC |

Description Key Example

BL 00x00, R LED-D, 24V-C

| | | | |
|--|--|--|--|
| Family Designation: BL - Backlight Backlight Size (mm - approx) | Color: R - Red W - White B - Blue G - Green I - Infrared | Delivery: D - Diffused Power: xxV-C - DC Volts Continuous CC - Constant Current | Source: LED - Light Emitting Diode |
|--|--|--|--|



Illumination & Electrical:

Light Characteristics:

| Source | Color (nm) | Exp. Life | CC-Strobe ^{1, 2, 3, 4} | | | CC-Continuous ^{1, 2, 4} | | |
|--------|---------------------|-----------|---------------------------------|---------|---------|----------------------------------|----------------------|----------------------|
| | | | Max. Current | Max. Vf | Min. Vf | Max. Current | Max. Vf ⁵ | Min. Vf ⁵ |
| LED | Red (625) | 50k hrs. | 2.00 A peak | 17.16 V | 11.32 V | 1.40 A | 14.04 V | 9.24 V |
| LED | Blue (470) | 50k hrs. | 1.90 A peak | 17.04 V | 11.92 V | 1.40 A | 15.96 V | 11.16 V |
| LED | Green (530) | 50k hrs. | 1.90 A peak | 17.04 V | 11.92 V | 1.40 A | 15.96 V | 11.16 V |
| LED | IR (850) | 50k hrs. | 2.00 A peak | 20.72 V | 12.96 V | 1.40 A | 19.20 V | 12.00 V |
| LED | White - 5500 Kelvin | 50k hrs. | 1.90 A peak | 17.04 V | 11.92 V | 1.40 A | 15.96 V | 11.16 V |

¹ CAUTION: Do not connect "CC" (Constant Current) lights directly to 24 volts; use a CC controller or driver.

² 24VDC +/- 3% is the recommended input to PP6xx controllers for CC-Strobe models;

24VDC +/- 10% is the recommended input to LCxx drivers.

³ Maximum pulse width = 1ms, maximum frequency = 60Hz

⁴ Exceeding max. current, pulse width or frequency voids product warranty.

⁵ Vf = Forward Voltage in Volts DC; used in calculating heat dissipation in CC-Continuous applications that use a PP6xx controller.

CE Conformity: Yes
Lighting Technique: Diffuse Backlight
Active Area: 250 mm x 200 mm (9.84 in. x 7.87 in.)

Environmental:

Max. Operating Humidity: 85% non-condensing
Operating Temp.: 40°C (104°F)
Storage Temp.: 50°C (122°F)

Mechanical:

L x W x H (mm/in.):

310.0 mm x 220.0 mm x 23.5 mm
 (12.20 in. x 8.66 in. x 0.93 in.)
 (4) 4.3 mm [0.17 in.] thru holes
 Black Anodized Aluminum
 Weight: 2.4 kgs. (5.2 lbs.)

Mounting:
Housing Material:
Weight:

Connectors:

Connector Type:

M12 "A" Code Male, 4 Pos:

Pin # 1 = +
 Pin # 2 = nc
 Pin # 3 = -
 Pin # 4 = nc
 Connector Shell = Shield

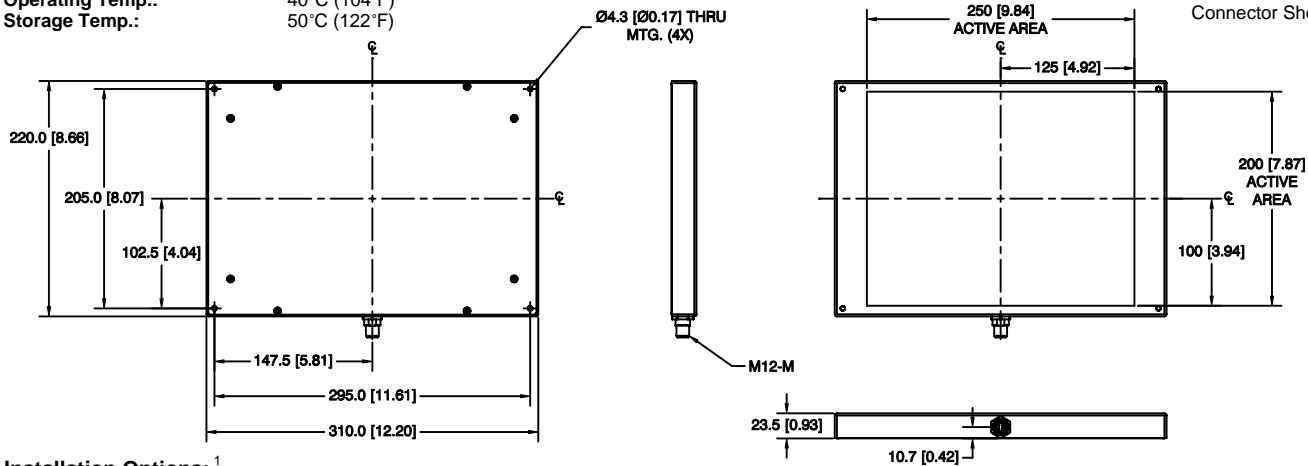

Installation Options:¹

| Part # | Description | Used on Models |
|--------------------|---|---------------------|
| 6GF3910-1BA10-0AS0 | PP600, 2 Chnl. CC Cntrl, 24VDC, Push Button ^{2, 3} | LT430 CC-Strobe |
| 6GF3910-1BA10-0AT0 | PP610, 2 Chnl. CC Cntrl, 24VDC, PB/RS232 ^{2, 3} | LT430 CC-Strobe |
| 6GF3910-1BA10-0AD0 | LC50, 1.4A CC Driver, w/Terminal Block ² | LT430 CC-Continuous |
| 6GF3910-1BA00-0AA0 | DSP60, 24VDC, 2.5A DIN Mount Power Supply | PP6xx & LC50 |
| 6GF3910-1BA00-0AB0 | DSP100, 24VDC, 4.2A DIN Mount Power Supply | PP6xx & LC50 |
| 6GF3910-1DA00-0AB0 | AC Power Cord, US, 1.8 M (6.0 ft.) | DIN Mount PS |
| 6GF3910-1DA00-0AC0 | AC Power Cord, EU, 2.5 M (8.2 ft.) | DIN Mount PS |
| 6GF3910-1DA00-0AD0 | AC Power Cord, UK, 2.0 M (6.6 ft.) | DIN Mount PS |
| 6GF3910-1DA00-0AA0 | Power Cable, Flying Leads - M12F, 3.0 M (9.8 ft.) | LT430 (all) |

¹ Constant Current (CC) controller or driver is required.

² CC controllers and drivers require a DC power supply; choose one from above.

³ Refer to [PP600 Heat Dissipation application note](#) if considering CC-Continuous mode applications (not recommended).

For further product family information see:

<http://www.nerlite.com>

Illumination uniformity graphs are available at...

<http://www.nerlite.com/pdfs/lt430-uniformity.pdf>



NERLITE LT430 BL 200x250 - 6599xx 121007



WARNINGS: For safe use of this product, observe the following warnings:



Handling: Surfaces hot during and after operation, avoid contact.



Service: No user serviceable parts inside, contact supplier for service.



Eye Safety: Products containing LEDs fall under the IEC standard for laser product safety (IEC 60825-1). Please refer to the IEC classifications and categorization of NERLITE products below for safe operation.



IEC Laser Safety Class Definitions pertinent to NERLITE LED products:

| IEC Class Code | Definition |
|----------------|---|
| 1 | Considered as safe to eye and skin under all reasonably foreseeable conditions of operation. |
| 1M | Considered as safe to eye and skin under all reasonably foreseeable conditions of operation, provided they are not viewed with magnifying optics of any kind. |
| 2 | Will not cause permanent eye damage under all reasonably foreseeable conditions of operation, provided that any exposure may be terminated by the blink reflex of the eye. Since this assumes the eye can detect this radiation, the wavelength range is limited to visible light (400nm to 700nm). |



IEC Laser Safety Class Codes of NERLITE LED Machine Vision Illuminators

| IEC Class Code | NERLITE Products (Refer to Model Descriptions) |
|----------------|--|
| 1 | R LED, W LED, G LED, I LED |
| 1M | U LED |
| 2 | B LED, B1 LED, B3 LED, R1 LED, R3 LED, W1 LED, W3 LED, G1 LED, G3 LED, I1 LED, DUAL AXIS LIGHTS containing I LED |



Training: Customers are encouraged to document their unique application and instruct employees on procedures to limit exposure to LED radiation. The documentation and instruction should include but not necessarily be limited to:

- Operational overview of equipment including LED lighting.
- Need for personal protection (e.g. protective eyewear, UV protective eyewear)
- Understanding hazard controls (e.g. warning signs)
- Bio-effects of LED radiation upon the eyes and skin (refer to <http://www.icnirp.de/documents/led.pdf> for the International Commission on Non-Ionizing Radiation Protection's statement on "LEDs and Laser Diodes: Implications for Hazard Assessment")



General LED Precautions:

These devices contain visible and non-visible LEDs – Light Emitting Diodes.



WARNING – RISK OF DISCOMFORT:

Observation of the Class 1 and 2 code definitions are substantial for eye protection.



Flashing LED Precautions:

This device contains LEDs – Light Emitting Diodes – that are flashing (aka strobing or pulsing) during operation.



WARNING – RISK OF DISCOMFORT:

Flashing (aka strobing or pulsing) lights have been known to cause discomfort in people; you can prevent this by taking precautions during use.



Ultra Violet (UV) LED Precautions:

This device contains UV Light LEDs – Ultra Violet Light Emitting Diodes. The LED during operation radiates intense UV light.



WARNING – RISK OF CORNEA AND LENS DAMAGE:

Viewing the LED output with certain optical instruments (for example: eye loupes, magnifiers and microscopes) within a distance of 100 mm may pose an eye hazard.

During operation, these LEDs radiate UV light, requiring that precautions must be taken to prevent looking directly at the UV light with unprotected eyes.

Do not look directly, or through an optical system, into the UV light. When there is a possibility to receive a reflection of light, protect your eyes by using UV light protective glasses so that light will not reach eyes directly.



Blue LED Precautions:

This device contains Blue LEDs – Blue Light Emitting Diodes.



WARNING – RISK OF RETINAL DAMAGE:

During operation, these LEDs radiate Blue light, requiring that precautions must be taken to prevent looking directly at the Blue light with unprotected eyes.

Eye protection from visible "blue light" LED radiation can be provided by normal aversion responses (e.g. looking away from light source, blink reflex).



Infra Red (IR) LED Precautions:

This device contains IR LEDs – IR Light Emitting Diodes.



WARNING – THERMAL HAZARD: RISK OF LENS DAMAGE:

During operation, these LEDs radiate non-visible thermal energy. Eye hazards are dependent upon brightness of the source and since IR LED output is non-visible, precautions must be taken to prevent looking toward the output of the LED assembly.