

# Basler *ace*

Area Scan Cameras

**GiGE**<sup>®</sup>  
VISION

GEN*i*CAM

CAMERA  
**Link**<sup>®</sup>  
REGISTERED PRODUCT



**CMOSIS models with  
Camera Link and  
up to 340 fps**

- Ground-breaking price starting at 299 euros
- Gigabit Ethernet interface with PoE
- Camera Link interface for high throughput with PoCL
- VGA to 5 megapixels with selected high quality  
CCD and CMOS sensors

**BASLER**   
VISION TECHNOLOGIES

*click. see. smile!*

# TECHNICAL DETAILS

## Specifications

Basler <i>ace</i>	Resolution (H x V pixels)	Sensor	Sensor Technology	Sensor Size (optical)	Pixel Size (µm)	Frame Rate	Power Consumption (PoE/AUX)	Weight (typical)
acA640-90gm/gc	659 x 494	Sony ICX424	Progressive Scan CCD	1/3"	7.4 x 7.4	90	3.1 W/2.7 W	<90 g
acA640-100gm/gc	659 x 494	Sony ICX618	Progressive Scan CCD	1/4"	5.6 x 5.6	100	2.3 W/2.0 W	<90 g
acA750-30gm/gc	752 x 580	Sony ICX409	Interlaced Scan CCD	1/3"	6.5 x 6.25	30	2.5 W/2.3 W	<90 g
acA1300-30gm/gc	1296 x 966	Sony ICX445	Progressive Scan CCD	1/3"	3.75 x 3.75	30	2.5 W/2.2 W	<90 g
acA1600-20gm/gc*	1628 x 1236	Sony ICX274	Progressive Scan CCD	1/1.8"	4.4 x 4.4	20		<90 g
acA2000-50gm/gc**	2048 x 1088	CMOSIS CMV2000	CMOS, Global Shutter	2/3"	5.5 x 5.5	50		<90 g
acA2040-25gm/gc**	2048 x 2048	CMOSIS CMV4000	CMOS, Global Shutter	1"	5.5 x 5.5	25		<90 g
acA2500-14gm/gc	2592 x 1944	Aptina MT9P	CMOS, Rolling Shutter	1/2.5"	2.2 x 2.2	14	2.5 W/2.2 W	<90 g

\* Available Q3/2011 \*\* Available Q4/2011

## Specifications Applicable For Gigabit Ethernet Models:

Mono / Color	Mono / Color
Interface	Fast Ethernet (100 Mbit/s) or Gigabit Ethernet (1000 Mbit/s)
Video Output Format	Mono 8, Mono 16 12 packed, YUV 4:2:2, Raw 8, Bayer BG8, Bayer BG16, Bayer BG12 packed, acA750gm/gc: Mono 8, YUV 4:2:2 packed, YUV 4:2:2 (YUYV) packed
Synchronization	Via external trigger, via the Ethernet connection or free run
Exposure Control	Freely programmable
Housing Size (LxWxH)	42.0 mm x 29.0 mm x 29.0 mm
Housing Temperature	Up to 50°C
Lens Mount	C-mount
Digital I/O	1 opto-isolated input / 1 opto-isolated output
Power Requirements	Via Power over Ethernet (802.3af) or + 12VDC (±10%) via the camera's 6-pin Hirose connector
Conformity	CE, FCC, IP30, RoHS, PoE (802.3af), UL (in preparation), GigE Vision, GenICam
Driver	Basler pylon SDK including filter and performance driver
Operating System	Windows, Linux - 32 bit and 64 bit

Specifications are subject to change without prior notice.

For detailed technical information, please see the camera manual that can be found on our website: [www.basler.com/manuals](http://www.basler.com/manuals)

## Dimensions (in mm)

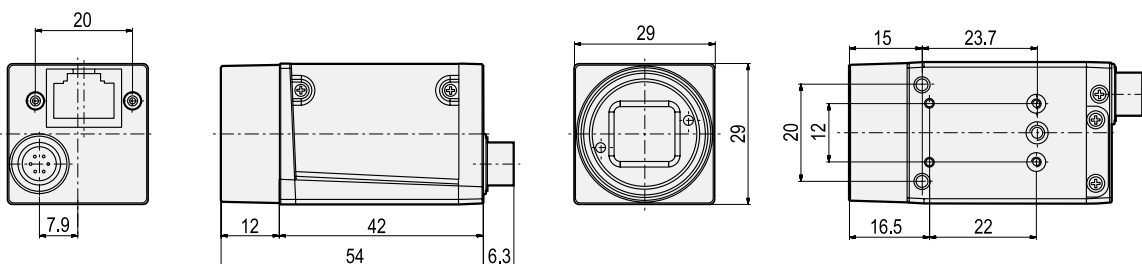

**Preliminary**

## Specifications



Basler <i>ace</i>	Resolution (H x V pixels)	Sensor	Sensor Technology	Sensor Size (optical)	Pixel Size (µm)	Frame Rate	Power Consumption (typical)	Weight (typical)
acA2000-140km/kc*	2048 x 1088	CMOSIS CMV2000	CMOS, Global Shutter	2/3"	5.5 x 5.5	140	<3.0 W	<90 g
acA2000-340km/kc**	2048 x 1088	CMOSIS CMV2000	CMOS, Global Shutter	2/3"	5.5 x 5.5	340	<3.0 W	<90 g
acA2040-70km/kc**	2048 x 2048	CMOSIS CMV4000	CMOS, Global Shutter	1"	5.5 x 5.5	70	<3.0 W	<90 g
acA2040-180km/kc**	2048 x 2048	CMOSIS CMV4000	CMOS, Global Shutter	1"	5.5 x 5.5	180	<3.0 W	<90 g

\* Available Q2/2011 \*\* Available Q3/2011

## Specifications Applicable For Camera Link Models:

Mono / Color	Mono / Color
Interface	Camera Link Base/Medium or Full
Synchronization	Via external trigger or free run
Exposure Control	Level controlled or programmable
Housing Size (LxWxH)	43.5 mm x 29.0 mm x 29.0 mm
Housing Temperature	Up to 50°C
Lens Mount	C-mount
Digital I/O	1 opto-isolated input or output
Power Requirements	12VDC (±10%), Power over Camera Link (PoCL) or via IO connector
Conformity	CE, FCC, RoHS, GenICam, Camera Link
Driver	Basler pylon Release 2.3 or newer
API for Configuration	Register API for C and VB6 or Basler pylon C++ API

Specifications are subject to change without prior notice.

## Dimensions (in mm)

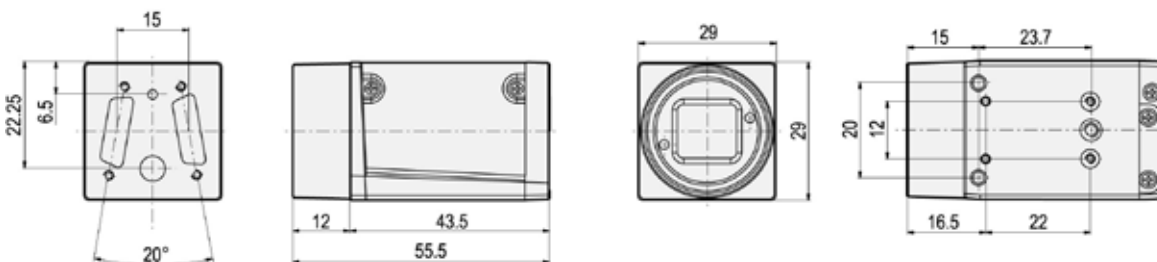

# Basler pylon Driver Package

The pylon driver package is designed to work with all Basler cameras that have a FireWire or GigE Vision interface. You can select the interface technology that best fits your application or you can use both interface technologies simultaneously in your application. The pylon driver offers reliable, real-time image data transport into the memory of your PC with a very low CPU load.

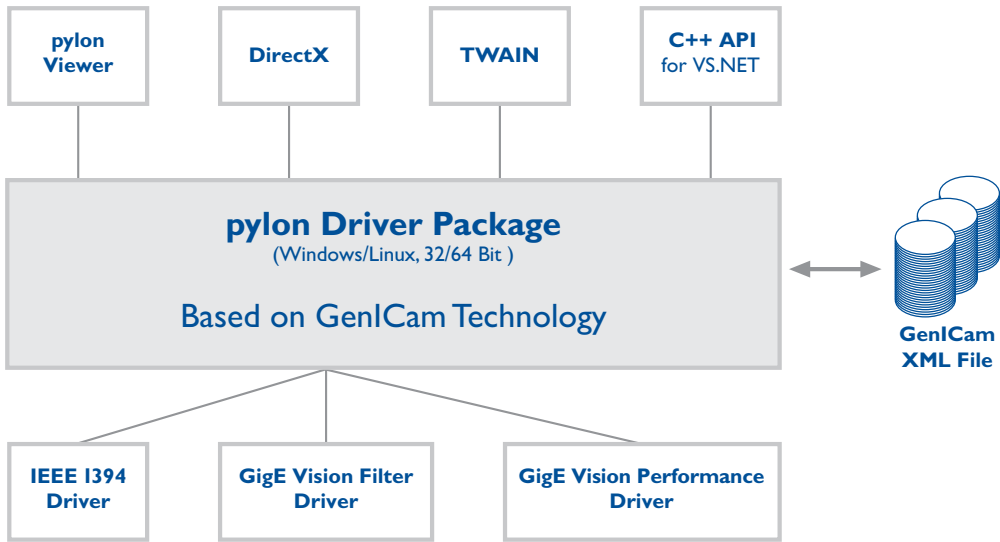

The internal architecture of the pylon driver package is based on GenICam Technology, which offers you easy access to the newest camera models and the latest features. Changes to an existing camera device in your application essentially become a plug-and-play process.

The pylon GigE Vision Performance Driver quickly separates incoming packets carrying image data from other traffic on the network and makes the data available for use by your vision application while requiring the lowest CPU resources. This driver can only be used with network cards that include specific Intel chipsets. The pylon GigE Vision Filter driver supports all kinds of

hardware, common GigE network cards, and GigE ports on your motherboard as well. The pylon IEEE 1394b driver gives you access to a well-established interface technology, but with double the bandwidth offered in the past. And by using the newest driver stack technology, Basler raises the quality of this service above the Microsoft standard.

The pylon Viewer offers you a convenient application for testing and evaluating Basler cameras. The new tree oriented design and the different levels of user access let you quickly and easily determine the best camera settings for your application.

## Basler ace Camera Series

### **Basler ace – one camera for all your needs**

For the first time, a Basler camera family covers the entire range from cost sensitivity to ultra-fast high performance in a very small 42 x 29 x 29 mm housing. The Basler ace series includes 18 CCD and CMOS models featuring the most popular resolutions from VGA to 5 megapixels with a fast throughput of up to 340 fps in monochrome and color. These cameras have a price-driven design that maintains our quality commitment by leveraging the technical knowledge we gained from our scout and pilot cameras and from our earlier A series cameras.

With the ace series, you can choose from the two most popular data interfaces in the vision market: the field-proven Camera Link interface with the widest bandwidth or the new de facto standard of GigE Vision, which is based on standard Ethernet technology. Both variants of the Basler ace family offer the option of providing camera power and data via a single cable or providing camera power through a separate connector. Both variants also offer a separate input/output port for triggering or flash control. And like all Basler cameras, the ace family comes with a long list of firmware features.

### **It has never been easier or less expensive to get better at what you do**

With a starting price of only 299 € and a design targeted for industrial, medical, and traffic applications, you can enjoy a new class of digital cameras that will help you to be even more successful at what you do. The entry price level for the new ace Camera Link models opens up new fields for gigapixel applications, such as AOI inspection or other throughput orientated applications. A Camera Link camera of this size has never before provided such performance. These ace cameras offer you clear advantages compared to classic Camera Link cameras with respect to size, weight, power consumption, temperature, and pixel output per second. This cost effectiveness opens up a new era of pricing in a camera class that used to be described as the “high end segment”.

### **Replacement with a smile**

Because the Basler ace uses the same 29 x 29 mm footprint that has been standard on analog cameras for many years, replacement of analog cameras is very easy. Some existing Camera Link cameras and IEEE 1394a or 1394b cameras with this same footprint can also be easily replaced. Because we have applied the same bottom mounting options to the Basler ace as seen on most standard analog cameras,

Basler has made mechanical replacement extremely simple. The use of a single cable to apply camera power and to transfer data between the Basler ace and a PC makes using these cameras even more convenient. The trigger speed and latency have been greatly improved, making integration easy, even in time-critical applications.

### **The height of GigE Vision perfection**

The Basler ace series benefits from our extensive experience designing and building GigE Vision cameras. As the pioneering GigE company, Basler has always kept our GigE Vision interface technology a step ahead of the competition. With the Basler ace, you get our bundled experience in GigE Vision, which lets you take the full advantage of our leading edge technology while benefiting from GigE Vision's newest achievements including:

- More than 100 megabytes of data per second
- Up to 100 meter cable lengths for maximum flexibility
- Power over Ethernet (PoE) support
- The field-proven Basler pylon driver package with both filter and performance drivers

### **No bandwidth limits with Camera Link**

The Basler ace is now also available with a standard Camera Link interface. Camera Link is a direct, single connection between the camera and a PC and offers the widest bandwidth of all common data interfaces. This is the best way for your application to exploit the full performance of the latest CMOS sensors from CMOSIS with no bandwidth compromises. These Basler ace models benefit from our long history and experience with high end area scan and line scan cameras and offer you:

- The widest bandwidth connection for maximum grabbing speed
- Minimum delay and jitter time for more accurate applications
- Compatibility with all common base, medium, or full configuration frame grabbers
- Power over Camera Link (PoCL) support

### **Accessories directly from Basler**

A wide selection of compatible, rigorously tested additional accessories is available from Basler to help simplify integration of the Basler ace series into your application. The range of accessories starts with simple things such as a tripod adapter and extends to power adapters or drag chain cables.

## How Does Basler Measure and Define Image Quality?



Basler is leading the effort to standardize image quality and sensitivity measurement for machine vision cameras and sensors. All measurements done by Basler will be in 100% compliance with the new European Machine Vision Association EMVA 1288 standard. Because it describes a unified way to measure, compute, and present the specification parameters for cameras and image sensors used in machine vision applications, Basler is giving the EMVA 1288 standard our strongest support.

The ace family will be characterized and measured to provide information about the quality and sensitivity of our products. All data can be found on Basler's website: [www.baslerweb.com](http://www.baslerweb.com)

## RoHS Compliance

The Basler ace series is RoHS compliant. This is especially important in applications where the end-user requires strict RoHS compliance in all system components.



[www.baslerweb.com](http://www.baslerweb.com)

**Germany, Headquarters**  
Phone +49 4102 463 500  
Fax +49 4102 463 599  
[bc.sales.europe@baslerweb.com](mailto:bc.sales.europe@baslerweb.com)

**USA**  
Phone +1 610 280 0171  
Fax +1 610 280 7608  
[bc.sales.usa@baslerweb.com](mailto:bc.sales.usa@baslerweb.com)

**Japan**  
Phone +81 45 227 6210  
Fax +81 45 227 6220  
[bc.sales.japan@baslerweb.com](mailto:bc.sales.japan@baslerweb.com)

**Singapore**  
Phone +65 6425 0472  
Fax +65 6425 0473  
[bc.sales.asia@baslerweb.com](mailto:bc.sales.asia@baslerweb.com)

**Korea**  
Phone +82 707 1363 114  
Fax +82 707 0162 705  
[bc.sales.korea@baslerweb.com](mailto:bc.sales.korea@baslerweb.com)