

Basler aViator

Area Scan Cameras

GIGE[®]
VISION

CAMERA
Link
REGISTERED PRODUCT

GEN<i>i>CAM

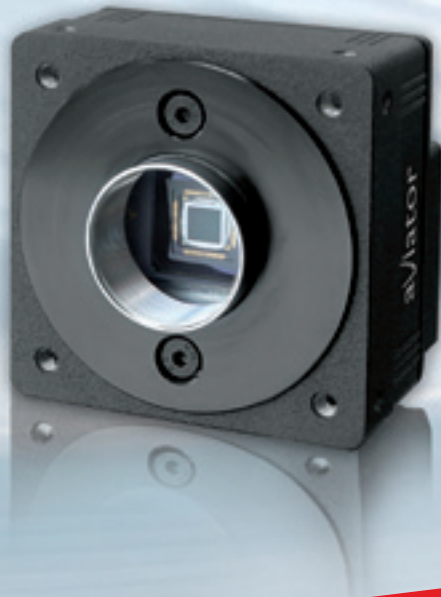

New GigE Camera Models

- One to four megapixels and up to 120 fps
- Brilliant CCD color with 12 bit image quality
- Kodak four tap sensor technology with the best tap balancing
- Extremely cost effective for new designs or system upgrades

BASLER
VISION TECHNOLOGIES

click. see. smile!

Basler aviator Camera Series

Fast CCD Technology at Its Best

The Basler aviator family is a series of high speed mainstream CCD cameras. Superior image quality, even at high image capture rates, makes a convincing argument for this advanced camera family. Basler aviator cameras are equipped with Kodak's latest CCD sensor generation with four tap readout technology. These sensors are up to four times faster than standard CCD sensors of the same resolution. With the aviator, Basler has applied the unique tap balancing competence we gained during the development of our earlier camera families such as the Basler pilot series, which also employs Kodak multi-tap sensors.

The aviator family offers:

- Excellent linearity, dynamic range, and noise level
- The best tap balance by performing individual tap calibration during production
- Fully automated production support using Basler's unique CCT+ production tool
- EMVA 1288 measurement reports to allow production quality monitoring

The Basler aviator series features progressive scan readout and global shutter technology. It offers camera models with resolutions of 1, 2 (4:3 and HDTV), and 4 megapixels, each in mono and color. More than 25 camera features, such as auto-gain and auto-exposure or the signal input debouncer, allow simple integration into many different applications and system environments. The aviator housing has a 62 mm x 62 mm footprint and provides screw holes for all five mounting positions. The industrially-proven aluminum body also includes screw holes for the safe locking of all cable connections.

Basler aviator Cameras Are an Ideal Fit for Applications Such As:

- Semiconductor manufacturing
- Electronics manufacturing
- Intelligent traffic systems (ITS)
- Metrology
- Medical imaging
- Various other applications



The Height of GigE Vision Perfection

Basler aviator GigE models benefit from our extensive experience designing and building GigE cameras. As a pioneering GigE company, Basler has always kept our GigE interface technology a step ahead of the competition. With the Basler aviator GigE models, you get this bundled experience that lets you take the full advantage of our leading edge technology.

Your benefits from our latest GigE achievements include:

- More than 100 megabytes of data per second
- Up to 100 meter cable lengths for maximum flexibility
- The field-proven Basler pylon driver package with both filter and performance drivers
- More than 25 camera features support easy system integration
- Attractive price/performance ratio

No Bandwidth Limits with Camera Link

Basler aviator Camera Link models are equipped with a standard Camera Link interface. Camera Link is a direct, single connection between the camera and a PC and still offers the widest bandwidth of all common data interfaces. This is the best way to integrate the full performance of the aviator's four tap Kodak sensors into your application with no bandwidth related delays. Basler aviator Camera Link models profit from our long history and experience with high end area scan and line scan cameras.

Your benefits from the aviator Camera Link models include:

- The widest bandwidth connection for maximum grabbing speed
- Compatibly with all common frame grabbers
- Additional opto-isolated I/Os for external devices (e.g., strobe)
- More than 25 camera features support easy system integration
- "GenICam over CL" or direct register access support
- Attractive price/performance ratio

Accessories Directly from Basler

A wide selection of compatible, rigorously tested additional accessories is available from Basler to help simplify integration of the Basler aviator series into your application. The range of accessories starts with simple things such as a tripod adapter and extends to power adapters or drag chain cables.

TECHNICAL DETAILS

Specifications



Basler a/viator	avA 1000-120km/kc	avA 1600-65km/kc	avA 1900-60km/kc	avA2300-30km/kc
Camera				
Resolution (H x V pixels)	1024 x 1024	1600 x 1200	1920 x 1080	2330 x 1750
Sensor	Kodak KAI-01050	Kodak KAI-02050	Kodak KAI-02150	Kodak KAI-04050
Sensor Size (optical)	1/2"	2/3"	2/3"	1"
Sensor Technology	Progressive Scan CCD, Global Shutter			
Pixel Size	5.5 µm x 5.5 µm			
Frame Rate	120 fps	67 fps	62 fps	31 fps
Mono / Color	Mono / Color			
Pixel Format	Mono 8, Mono 10, Mono 12, Bayer GR8, Bayer GR10, Bayer GR12			
Interface	Camera Link (base), single 26-pin MDR connector			
CL Pixel Clock	32.5, 40, 48, or 65 MHz (selectable via software)			
CL Tap Geometry	1X2-1Y or 1X-2YE			
Synchronization	Via external trigger or free-run			
Exposure Control	Trigger width or timed			
Mechanical / Electrical				
Housing Size (L x W x H)	57 mm x 62 mm x 62 mm			
Housing Temperature	Up to 50°C			
Lens Mount	C-mount			
I/O Ports	2 opto-isolated input / 1 opto-isolated output			
Power Requirements	12VDC (±10%) via 6-pin Hirose connector			
Power Consumption (typical)	5.0 W	5.5 W	5.5 W	6.0 W
Weight (typical)	<300 g			
Conformity	CE, FCC, IP30, RoHS, GenICam			
Software Environment				
Configuration Software	Basler pylon release 2.2 or higher			
API for Configuration	Register API for C and VB6 or Basler pylon C++ API			

Specifications are subject to change without prior notice.

For detailed technical information, please see the camera manual that can be found on our website: www.baslerweb.com/manuals

Dimensions (in mm)

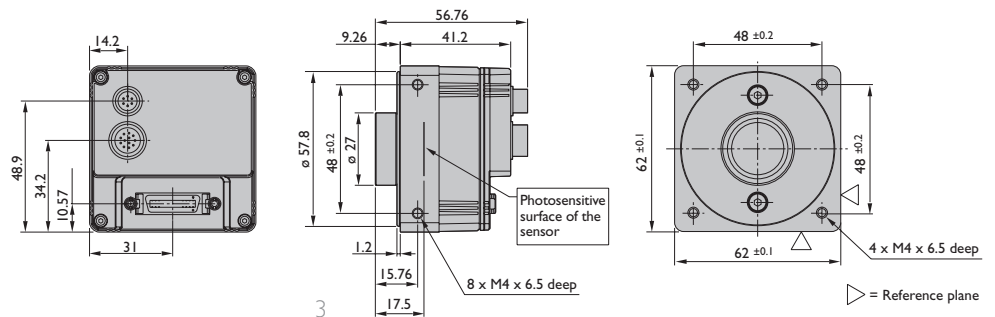

TECHNICAL DETAILS

Specifications



Basler a/viator	avA1000-100gm/gc	avA1600-50gm/gc	avA1900-50gm/gc	avA2300-25gm/gc
-----------------	------------------	-----------------	-----------------	-----------------

Camera				
Resolution Size (H x V pixels)	1024 x 1024	1600 x 1200	1920 x 1080	2330 x 1750
Sensor	Kodak KAI-01050	Kodak KAI-02050	Kodak KAI-02150	Kodak KAI-04050
Sensor Size (optical)	1/2"	2/3"	2/3"	1"
Sensor Technology	Progressive Scan CCD, Global Shutter			
Pixel Size	5.5 x 5.5 µm			
Frame Rate	>100 fps	>50 fps	>50 fps	>25 fps
Mono/Color	Mono/Color			
Video Output Format	Mono 8, Mono 16, Mono 12 packed, YUV 4:2:2, Raw 8, Bayer BG8, Bayer BG16, Bayer BG12 Packed			
Interface	Gigabit Ethernet (1000 Mbit/s)			
Synchronization	Via external trigger; via the Ethernet connection, or free-run			
Exposure Control	Freely programmable			

Mechanical / Electrical				
Housing Size (L x W x H)	57 mm x 62 mm x 62 mm			
Housing Temperature	Up to 50°C			
Lens Mount	C-mount			
Digital I/O	2 opto-isolated input / 4 opto-isolated output			
Power Requirements	12 VDC (±10%) via 12-pin Hirose connector			
Power Consumption (typical)	5.0W	5.5W	5.5W	6.0W
Weight (typical)	<300 g			
Conformity	CE, FCC, IP30, RoHS, GenICam, GigE Vision			

Software / Driver				
Driver	Basler pylon SDK including filter and performance driver			
Operating System	Windows, Linux - 32 bit and 64 bit			
Conformity	GigE Vision, GenICam			

Specifications are subject to change without prior notice.

These cameras will be available Q1/2011

For detailed technical information, please see the camera manual that can be found on our website: www.baslerweb.com/manuals

Dimensions (in mm)

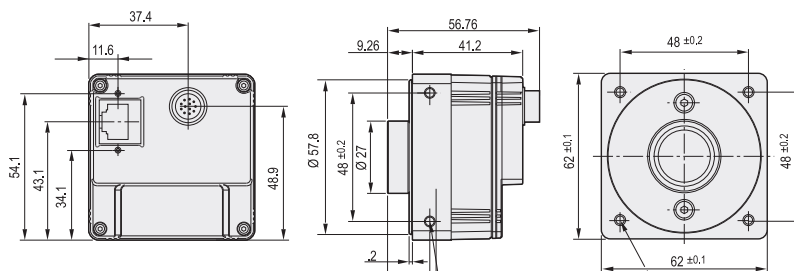

What Makes Basler Camera Quality So Special?



To ensure consistently high product quality, we employ several quality inspection procedures during manufacturing. The following list describes some of the most essential actions we take to meet your highest requirements:

- The back focal length on each camera is carefully measured and adjusted. This guarantees an optimum distance between the lens flange and the sensor and ensures compliance with optics standards.
- Our advanced Camera Test Tool (CTT+), the first fully-automated inspection system for digital cameras, checks all of the significant quality aspects of each camera we produce. The CTT+ is a unique combination of optics, hardware, and software that can be quickly and efficiently used to calibrate a camera and to measure its performance against a set of standards. For defined sets of conditions, an automated software program examines the camera's output, makes any calibration adjustments necessary, and compares the output to a strictly defined set of performance criteria.

How Does Basler Measure and Define Image Quality?



Basler is leading the effort to standardize image quality and sensitivity measurement for machine vision cameras and sensors. All measurements done by Basler will be in 100% compliance with the new European Machine Vision Association EMVA 1288 standard. Because it describes a unified way to measure, compute, and present the specification parameters for cameras and image sensors used in machine vision applications, Basler is giving the EMVA 1288 standard our strongest support.

The aviator family will be characterized and measured to provide information about the quality and sensitivity of our products. All data can be found on Basler's website: www.baslerweb.com

RoHS Compliance

The Basler aviator series is RoHS compliant. This is especially important in applications where the end-user requires strict RoHS compliance in all system components.





www.baslerweb.com

Germany, Headquarters

Phone +49 4102 463 500
Fax +49 4102 463 599
bc.sales.europe@baslerweb.com

USA

Phone +1 610 280 0171
Fax +1 610 280 7608
bc.sales.usa@baslerweb.com

Japan

Phone +81 45 227 6210
Fax +81 45 227 6220
bc.sales.japan@baslerweb.com

Singapore

Phone +65 6425 0472
Fax +65 6425 0473
bc.sales.asia@baslerweb.com

Korea

Phone +82 707 1363 114
Fax +82 707 0162 705
bc.sales.korea@baslerweb.com