

Prosilica GX-Series: 240MB/s The Fastest GigE Cameras in the World



Description

The new 2/3" format, HD-resolution, 2 megapixel GX1910 is a high-resolution CCD camera with GigE Vision® Gigabit Ethernet interface. The GX1910 incorporates the new Kodak KAI-02150 CCD sensor excellent image quality in HD resolution (1080p).

The GX1910 has two screw-captivated Gigabit Ethernet ports configured as a Link Aggregation Group (LAG) to provide a sustained maximum data rate of 240 MBytes per second.

The GX1910 runs 63 frames per second at 1920x1080 resolution and even faster with region of interest readout. The GX1910 works with standard gigabit Ethernet hardware and cables and can have cable lengths up to 100 meters (300 ft) long using conventional Cat5e.

Highlights

- 2/3" format - HD resolution (1920x1080)
- Kodak KAI-02150 Progressive interline CCD
- Thermal management enclosure
- Global shutter (Snapshot shutter)
- Fast frame rate - 63 fps at full-resolution
- Gigabit Ethernet interface - Dual Port 240 MB/s
- GigE Vision compliant
- Motorized lens controls - 3-axis
- Video-type autoiris controls
- Asynchronous external trigger and sync I/O
- 128 MB resend/image buffer
- Screw-captivated power connection
- Software development Kit

Dimensions

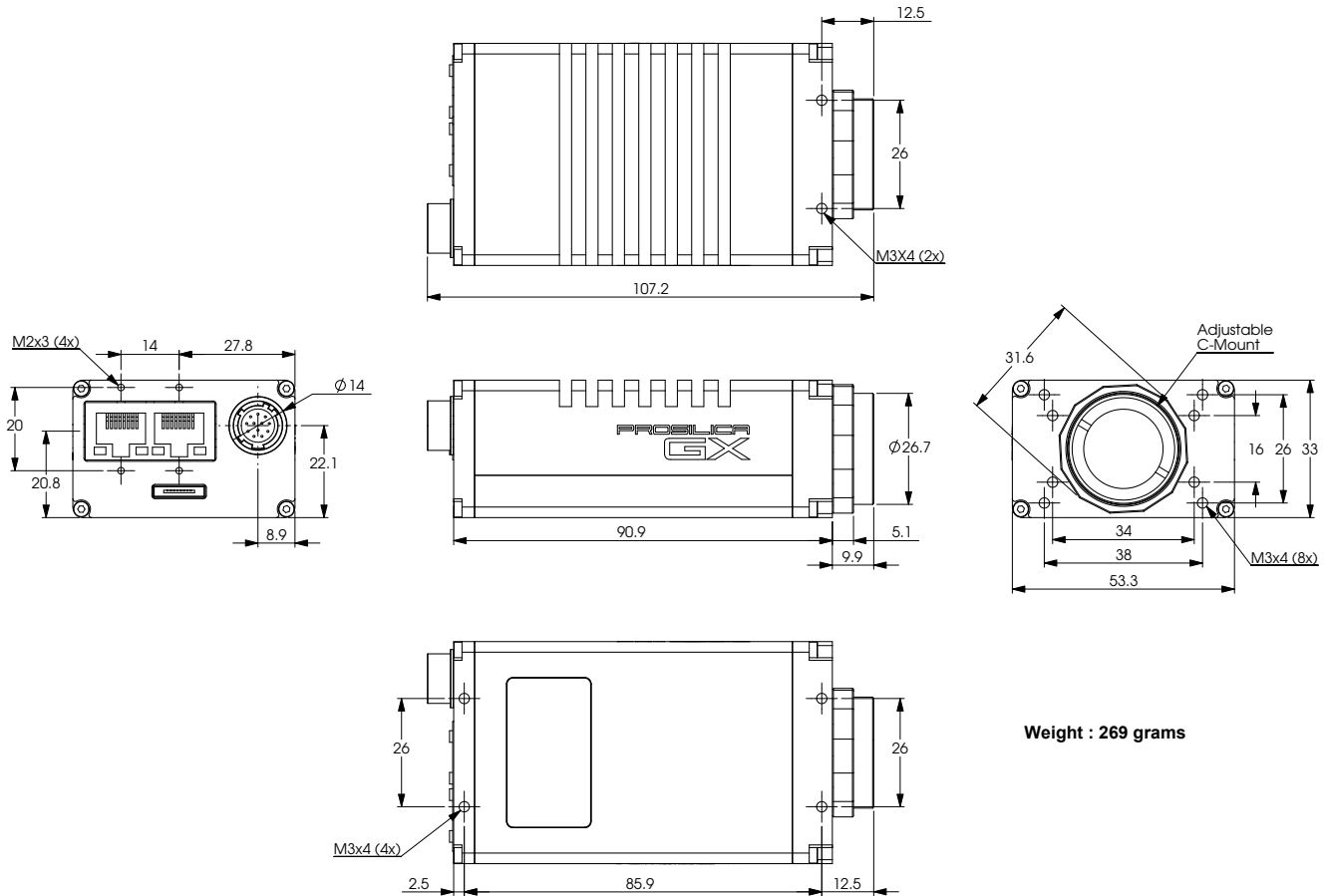

Weight : 269 grams

Interface: Dual Gigabit Ethernet Ports Featuring LAG Technology



Camera Specifications	GX1910 / GX1910C
Resolution	1920x1080
Sensor Type	2/3" CCD progressive interline Kodak KAI-02150
Pixel Size (µm)	5.5 x 5.5
Maximum Frame Rate (full resolution)	63 fps
Lens Mount	C-mount with adjustable back focus
Digital Interface*	GigE Vision 1.0
Interface Type	IEEE 802.3 1000base-T, 100base-TX
Exposure Range	10µs to 60s
Gain Range	0 to 34dB
Region of Interest (ROI)	Independent x and y control; 1 pixel resolution
Frame Rate at 100 x 100 ROI**	TBD
Binning	Independent H and V control; 1 pixel resolution
Horizontal Binning Range	1 to 8 pixels
Vertical Binning Range	1 to 8 rows
2x2 binning max. framerate	TBD
Imaging Modes	Free-running, External Trigger, Fixed frame rate, Software trigger
Fixed Frame Rate Control	0.001 fps to maximum frame rate
External Trigger Modes	Rising edge, Falling edge, Any edge, Level high, Level low
External Sync Modes	Trigger ready, Trigger input, Exposing, Readout, Imaging, Strobe, GPO
Trigger Delay Control Range	0 to 60s in 1 µs increments
Trigger Latency	1.5 µs
Trigger Jitter	+/-0.5 µs
External Trigger/Sync Connection	mini-SMB and 12-pin Hirose
Monochrome Modes	Mono8, Mono16†
Color Modes	Bayer8, Bayer16, RGB24, YUV411, YUV422, YUV444, BGR24, RGBA24, BGRA24
GPIO	2 isolated TTL input, 4 isolated TTL outputs, RS232 TX/RX, motorized iris, video auto-iris, focus and zoom
Max. Power Consumption	<5.6W using a single GigE port <6.7W using 2 GigE ports
Max. Operating Temperature	50 C
Housing Size (not including lens mount and connectors)	33 x 53.3 x 90.9 mm
Total Size Envelope (HxWxL)	33 x 53.3 x 107.2 mm
Nom. Weight	269 g
Conformity	CE, FCC, RoHS
Digitization	14 bits
Spectral Sensitivity Range	325 - 1000 nm

Specifications are subject to change without notice.

*GigE Vision® is a trademark of the Automated Imaging Association.

**These figures are given as an example. There are a wide range of settings and speeds possible. Smaller ROI and/or higher binning modes will give even faster maximum framerates.

†Mono16 is available on monochrome models only.